



# UTAH VALLEY

## *- Model A Club -*

June 2015

IN THIS EDITION:  
**HEBER CREEPER TOUR**  
Golden Wrench Award  
2016 National Convention

RAT FINK  
OVER-  
NIGHTER

ELECTRICAL  
REPAIRS ON  
THE MODEL A



Photographer, Allison Mack

### WHAT'S INSIDE:

- |                             |                             |                                    |
|-----------------------------|-----------------------------|------------------------------------|
| 2 President's Message       | 8 Heber Creeper Tour        | 14 Electrical Repairs on a Model A |
| 3 2015 Calendar of Events   | 10 2016 National Convention | 15 Breaking News...                |
| Wisdom of Henry Ford        | 11 Guess Who?               | 16 Ladies Fashion Journal —        |
| Birthdays                   | Out and About               | Collar, Cuffs, Sleeves & Belts     |
| 4 May Meeting Summary       | 12 Golden Wrench Award      | 19 MAFCA News                      |
| 5 Guess Who?                | Tony Jacobs                 | 24 "Now a Word from our            |
| Out and About               | 13 Model A Adventures —     | Sponsors"                          |
| 5 We're Having a Sleep-over | The Day We Learned About    | 24 Elk Ridge Car Show              |
| Rat Fink Reunion            | Spare Parts                 |                                    |



The purpose of the club is two-fold:

1. To serve as a medium of exchange of ideas, information, and parts for admirers of Model A Ford cars and trucks and to aid them in their efforts to restore and preserve these vehicles in their original likeness.
2. To unite in a central organization, all individuals who are interested in restoring the automobile in a manner to attract prestige and respect within the community. It shall further be the purpose of this club to help these individuals become better acquainted and encourage and maintain among its members the spirit of good fellowship, sociality, and fair play through sponsored activities including the use of the Model A Ford and family participation.

The Utah Valley Model A Club is a chapter of the Model A Club of America (MAFCA).

**2015 Club Officers**

**CLUB OFFICERS**

President	Howard Eckstein
Vice President	Greg Mack
Secretary/Historian	Elaine/Reid Carlson
Treasurer	Diane/Brim Brimley

**APPOINTED POSITIONS**

Web Page	Nicholas & Greg Mack
Facebook	Clyde Munson
InstaGram	Fernando Salazar
Photographer	Greg Mack
Activities	Nicholas Mack
Awards	Kelly Barker
Newsletter	Robert Mack

# Message from President Howard Eckstein

## The Model A as Part of Our Chemistry

I remember learning in science class that a catalyst is something that is put in a chemical system to cause a reaction. The catalyst is not consumed, but without it the reaction won't work. Under this definition, our Model As are catalysts.

When you are with your Model A, things happen. Strangers introduce themselves and will often tell you a story. People smile and wave when you drive by. Whenever you work on it you learn something new. And with our club, members help each other and the helpers and the helpees grow in the process.

We saw members benefit each other during our Driver Training day. Seasoned drivers learned some ways to drive their cars better. New drivers got introduced to the Model A under the watchful eyes of our instructors. During April's Garage Day, Tony went home with working lights on his Phaeton.

Whenever we meet together, there is a lot of looking at each others' cars to compare notes. I got to drive some other cars and in so doing, saw things I want to improve on mine.

One car I drove was out for its first club outing and is still a work in progress for its owner. The brakes on that car needed adjustment. We got together with the owner and showed him how to adjust the brakes and brought them up to snuff right there and then. No club event is ever complete without someone's hood up and other members looking on while expert advice is floating around in the air.

Our Model As truly are catalysts. Your car will cure you of shyness, enlarge your circle of friends, keep you tinkering, and increase your Fun Quotient by a magnitude unknown to science.

Howard



# 2015 Calendar of Events

## June

- 4-6th — Rat Fink/San Pete County Overnighter. Turkey BBQ, touring, car show, live radio show and more!
  - 7-12th — 2015 MAFCA National Tour: more details on the MAFCA page 22.
  - 8-12 — Regional Meet, "A's in N.W. Missouri:" again, more details on the MAFCA page 22.
  - 23-27th — Northwest Regional Meet, Walla Walla Washington.
- See page 22 for further details.
- 27th — Elk Ridge Car Show and Drive in Movie. Show 4:00 till dusk followed by movie.



## July

- Board Meeting
- 16th Monthly Meeting 7:00 p.m.
- 24th — Pioneer Day Parade, Mapleton

## August

- 3rd — Board Meeting 8:00 p.m.
- 3rd — Lindon Car Show, 4 p.m. to 8 p.m.
- 20th — Monthly Meeting, Larry H. Miller, 7 p.m.
- TBA — Progressive Dinner

## September

- 8th — Board Meeting 8:00 p.m.
- 17th — Monthly Meeting Larry H. Miller 7 p.m.
- 12th — International Model A Day. Manifold Cook Off and Fall Colors

## October

- 8th — Board Meeting 8:00 p.m.
- 10th — Monthly Meeting, Larry H. Miller, 7:00 p.m.

## November

- 8th — Board Meeting 8:00 p.m.
- 10th — Monthly Meeting Larry H. Miller, 7:00 p.m.

## December

- TBA — Christmas Dinner

## The Wisdom of Henry Ford

*There is joy in work. There is no happiness except in the realization that we have accomplished something.*



Happy Birthday

Wendell Gadd — June 6th  
 Reid Carlson — June 21st  
 Bill Thompson — June 27th



# May Meeting

TAKEN FROM MINUTES PREPARED BY REID CARLSON

## Attendance:

Bob Durrant, Lloyd and Kelly Barker, Howard and Gemma Eckstein, Reid and Elaine Carlson, Vern Cope, Fernando Salazar, Ron and Ellie Sessions, Bill and Colette Thompson, Alan and Pat Justensen, Nicholas, Greg and Robert Mack, Dale Bench, Clyde Munson.

**Another New Member!:** Bud Durrant is a new member who joined with us during the Heber Creeper excursion. He has a great looking green and black coupe.

## Future Meetings Presentations:

- **June** - Howard will give a demonstration on upholstery.
- **July** - Reid will cover carburetors, and Kelly Barker will talk about horn maintenance.
- **August** - Vern will demonstrate bodywork techniques.

At the last garage seminar we fixed the lights on Tony's Phaeton and made several bumper seats. Following the activity, Howard bought new reflectors and other components and replaced the headlights in his car. He stated that the lights are better now than any time he has owned the car.

**Up-coming Activities:** Our first overnigher is scheduled for June 5-6th to San Pete county for the Rat Fink Reunion. The Manti crew discussed the events and itinerary for the weekend. It looks to be a lot of fun. All the cars made it to Heber without a problem, there is no reason they can't make it to Manti. Look for more details later in this issue on pages 5-7.

## Presentations:

### Brakes

Using his skills as an artist Clyde used drawings to explain how the brakes worked; how the front brakes were different than the back brakes and what crucial parts of the system are often overlooked.

Clyde also discussed the importance of correct adjustment of the brakes for maximum efficiency. Many people think hydraulic brakes are better than mechanical, but Clyde explained that the braking action takes place where the rubber meets the pavement. If mechanical brakes are in good condition, cast iron drums are used and there is no slack in the rods and pins, mechanical brakes are just a efficient.

### Fashions

What could make your car look better? Why do people wear period clothing while driving their Model A's? Passersby are intrigued by the old cars we drive and enjoy looking at them. They are even more enamored by the old cars when the people driving them are dressed in period clothing that original owners might have worn.

Elaine and Reid Carlson have taken this to heart and have long dressed the part. Now Elaine, with Reid's help has challenged us to do the same. She gave a presentation concerning fashion that was top notch. She had sample dresses and both Elaine and Reid wore their period dress. She give us handouts to start with and is willing to help anyone who wants to learn how to dress the part.

**13+ Award:** Vern was the one that initiated the 13+ award and has worked hard to get his. He completed the number of drives and qualified a couple of months ago. Congratulations Vern you are one of seven people who have earned it so far.



# We're Having A Sleep-Over!

## MANTI RAT FINK REUNION

June 5-6  
2015

And we're off on another another family fun event! We will be meeting at Burger King in Springville at 8:30 a.m. on Friday, June 5th, and tour to Manti together. We will be taking all backroads to Nephi and then up the canyon into San Pete county. Karl and Diane are bringing a trouble trailer.

Make sure you bring your camera, extra clothing, sunscreen, water bottles, a camp chair and extra car parts, if you have them. We have plenty of room in the trouble trailer for all your gear.

One we depart Springville, we will be heading south on UT198 through Spanish Fork, Salem and Santiquin. Once at Santiquin we'll follow old highway 91 past the Red Barn and the Young Lavender farms. We'll stop in Nephi for a bathroom and gas break.

Leaving Nephi we'll travel along UT32 through the canyon into Sanpete county. We will pass through Fountain Green, Moroni and Ephraim into Manti where we'll stop for another potty and gas break. We'll saddle-up one more time for a short drive into Sterling past the Palisades Golf Course to our destination of Cedar Crest Inn. We will check-in. Please have cash or a check for payment. We will have a turkey BBQ at 12:30 (\$7.00 per person) hosted by the club. Then we're off to Spring City.



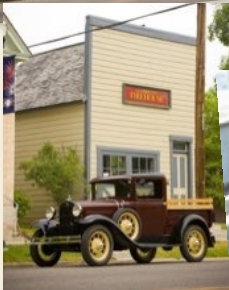

### FRIDAY

- 8:30 Leave Burger King parking lot in Springville
- 12:00 Check in Cedar Crest Inn
- 12:30 Turkey Barbecue
- 1:30 Spring City Tour
- 4:00 Rat Fink Museum  
UVMAC cars on display
- 5:30 BBQ Dinner at Rat Fink Museum
- 6:30 Free Time
- 8:30 Banana Splits at Rat Fink Museum

After lunch we will travel together to Spring City. There are so many historic homes with fascinating stories behind them the whole town has been designated an historic district. We will drive by many of them to learn about their stories. There are many great places to take pictures of your family with or without your car so be sure to take your camera with you!

Depending on time and interest we will travel a few miles to Fairview and take in the Museum of History and Art. There they have a full size dinosaur skeleton on display as well as exhibits on local pioneer history and art.

At 4:00 p.m. we need to be back to Manti at the Rat Fink Museum where our cars will be on display. At 5:30 p.m. there is a BBQ dinner at the museum (cost not known at this time). Take time to visit the museum and pick up a few souvenirs.

From 6:30 to 8:30 there is free time. This may be an opportunity to visit the Manti Temple grounds and get a club picture with the temple in the background.

If you have any energy left, there is a banana split party at the Rat Fink museum, or you can stock up on supplies and have your own at the Cedar Crest Inn.



SATURDAY

- 7:30 Check out for those leaving today
- 8:00 Car Show, Manti
- 10:00 Silent Auction
- 10:30 Band Concerts
- Noon Live Auction
- 2:00 Silent Auction results
- 3:00 Car Show awards
- 5:00 Parade & Cruise Main St.
- 6:00 Those going to Radio Show leave for Spring City
- 6:30 Dinner, Roth residence for those not going to the Radio Show



SUNDAY

Church for those interested



On Saturday we'll have another full day as the schedule above shows. For those leaving today you will need to check out. Those participating in the car show will need to be there early. Others can spend the morning as they like. The club will be inviting other Model A enthusiasts to join us, so help out if you can.

There will be activities through-out the day so watch the schedule closely so you don't miss anything. Lunch will be on our own today, but stop by the park at 3:00 p.m. so you can hear the winners of the car show. Who knows we might have a winner or two — we usually do. There will be a car parade down main street at 5:00 p.m. that should be a lot of fun.

At 6:00 those going to the Old Time Radio Show will need to leave. Those going home today will have Karl Furr following with the trouble trailer.



On Sunday, those who are interested can attend church, then we will travel back to Utah county together. It should be a great time. Don't Miss it!



# The Heber Creeper Tour

Thirty-two people and seven cars took up Cliff Godfrey's invitation to "ride the rails." Karl and Diane Furr, Clyde and Jenn Munson, Bob Anderson, Howard and Gemma, Dale and his daughter, Diane and Margaret with their family, Richard Burr, and Greg, Nicholas, Becky, Allison, and Robert Mack met at Harmon's parking lot in Orem on Saturday, May 9th and headed up the canyon. Munsons, Macks, Richard, Brimleys and Ecksteins all drove their Model A's.

The ride up Provo Canyon was gorgeous. The rain brought out all the colors in the trees, rock formations, a other plant life. The clouds hung low hiding the tops of the canyon walls, giving them a foreboding feeling of what might lay ahead. We felt a few drops here and there but that was all. Now on the way back, that was a different story.

As we pulled into Heber we were joined by another Model A Coupe that most of us had not seen before. It was Bud and Connie Durrant, friends of Cliff. Cliff's other Model A friends, also joined us. We were also met by the Manti crew (Bill, Colette, Ron, Ellie, Alan and Pat). Diane, Margaret and family and Elaine and Reid brought up the rear with Betsy.

Cliff loaded us all on the train and with a toot of the whistle, we were off. The railroad cars were heated so it was nice and cozy, but that steamed the windows so we were either wiping them clean or opening the windows every time we wanted to take a picture. Needless to say there was a lot to take pictures of.

About half way down we made an abrupt stop. There was some yelling in the car in front of us and all of a sudden two cowboy clad gunmen/women (one was a guy and the other a gal) came bursting into the car with guns held high yelling at the top of their lungs! It scared the club members on that end of the car. They shouted for everyone to raise their hands, which we did. Then they went down the rows liftin' loot

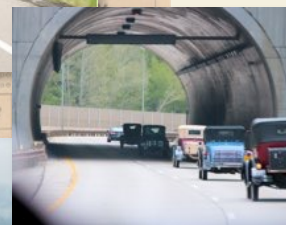





from the passengers. The gunman told Pat to stand up. He asked her if she could cook, she was smart enough to say no. Then he asked her if she could sew, again she said no, finally he asked her if she could skin a deer. When she replied with the third “no” he told her she wasn’t worth kidnapping and to sit down.

Next he approached Diane Furr. We were afraid she might be kidnapped, and Karl made no moves to defend her. But alas, she was allowed to remain with the group. With all the noise, raised hands and guns present it was a harrowing experience! In the pictures to the left you can see how scared everyone was.

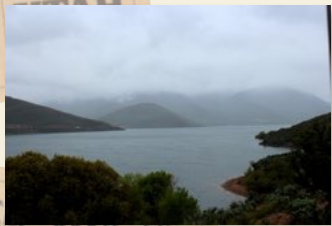

Once we reached the Deer Creek Dam they uncoupled the locomotive, brought it around the train and we started back to Heber. On the return trip Cliff arranged to have a cowgirl (who coincidentally looked a lot like the gun-woman) pulled out her guitar and serenaded us for the better part of the return trip.



Toward the end of the ride Cliff got our brains working with a quiz which the group, as a collective effort, only got about 50% right.

Back at the station we all disembarked; relieved that we had all arrived safe and sound. The robbers didn’t get our money, but the gift shop did. Then we caravanned over to Dairy Keen, ate and watched the model trains overhead, while we chatted and enjoyed each other’s company.



All the cars performed marvelously. We had no problems at all. The trouble trailer was empty both ways. The next time you hear the call “All Aboard!” make sure you join us for another great time! Thanks Cliff!

*Photographers: Howard Eckstein, Allison and Greg Mack*



# 2016 MAFCA National Convention

**JUNE 19-24; LOVELAND, COLORADO**



### **IT'S COMING... JUST LIKE CHRISTMAS!**

The editor has been telling you to plan for the national convention to be held in 2016 in Colorado for quite some time now. Well, just like Christmas it's coming fast. If you haven't started putting a little money away monthly you've got to start putting money in the piggy bank now! Mark on your calendar so nothing can get in the way. Make sure your family knows you've calendared those days for the convention so they don't schedule weddings, blessings or family reunions at that time. It's MODEL A TIME!

### **SIGHTS AND ATTRACTIONS**

### **WHEN, WHERE, WHAT AND HOW**

**When:** June 19-24th  
**Where:** Loveland, Colorado  
**Who:** Mile High Model A Club  
**At:** The Ranches

Every other month we'll highlight some of the attractions, events and tours available during or after the convention. So, watch closely and start planning what you want to do and see while you're there.

At the last national convention there were hundreds of Model A's at the convention center. Driving the side roads, Model A's could be seen — all models, colors and conditions. Model A "talk" was the universal language. We'll have a great time together and meet lots of new friends! Come join us!

Visit: <https://www.youtube.com/watch?v=Z4YB0vbqztg&feature=youtu.be> for more information.

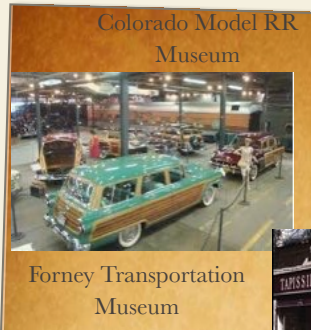

Antique Mall

Downtown Fort Collins



Largest train store



Ft Collins Municipal Railway



Rocky Mountain NP



Bert's Model A Unsinkable Molly Brown's Home



Indoor Flea Market





# Can You Guess?

MYSTERY SLEUTH

## Whose Car is This?

By reading through the newsletter this month you will be able to figure out who owns this nice coupe.



Believe it or not, this is Carlson's car. Reid came across this when he was going through some of his old photos. Betsy has gone through quite a transformation. She's in her best finery with an extreme makeover.



# Out & About

Tony is at it again. He won another award with his car. He braved the rain and took his phaeton to the U V U car show at Thanksgiving Point. He won an award for the best convertible in his category!



Congrats Tony!

Jim and Janette Haire have moved back to California to be with family, so he donated some old *Restorer* magazines to the club. Thanks Jim!

Janell and Bob Todd's youngest son Sam was married and, as you can see, Bob's Roadster played an integral part.





# Golden Wrench Award

by Tony Jacobs

When I purchased my phaeton it didn't have a windshield wiper. When I restored it I didn't install one.

For years I have been collecting Model A parts, just like most of us do. While going through these parts I ran across a windshield wiper and decided it was about time to install one. The pictures to the right show me installing the "new" wiper.

While I was working on the car I decided it was time to spruce up the engine, the paint was showing it's age so I purchased the Ford green paint for the engine, did the prep. work on cleaning and degreasing the engine, then I masked, or took off, the parts that weren't suppose to be painted and re-painted the engine block. From the photos you can see the before and after. It makes quite a difference!

As you can see by the first photo, my next project is to rebuild and replace my speedometer and cable.

When you own a Model A there is always something that can be done to improve it.

Tony





# Model A Adventures — The Day We Learned About Spare Parts

BY HOWARD EKSTEIN

Shortly after I got my driver's license, my dad and I were driving my Model A after having done some work on it. He said: "Do you hear that sound? That's the rear end singing." I was new to car mechanics and really didn't understand how a singing rear end would impact my life, except that maybe the sound would get louder and it would be harder to have a conversation while driving around.

Dad said we needed to find another one to avoid the expense and craftsmanship required to set up new gears and bearings for the one in the car. In the mid '60s, we could still find ads in the local newspaper for Model A parts. Some guy in Van Nuys had two differentials for sale. We went over there and picked out the one we thought was the best and paid him \$30 for it.

When we got home, we jacked up the car and started removing the old axle. We got the new one nearly installed when my dad discovered that it had been taken apart before and reassembled with the drain holes on the top of the banjo.

"You're not going to be able to drain and fill it like that." He said. "But it's symmetrical, so we can take it back out, flip it over, and rotate the axle housings a half-turn to put the spring hangers back on the top." By the time we got it halfway back in the car, it was dark and time to quit.

The following Monday, I asked my friends if they'd help me finish buttoning up the project. It didn't take us long and I was eager to find out if this new axle was quieter than the old one.

I started the car, put it in reverse and twisted myself around so I could see to back out. The car went forward. I tried once more and the car again went forward. Deeply puzzled, I tried first gear and the car backed up. Now I panicked. I tried second and high and the car went in reverse in both selections.

I was beside myself wondering what I had done to my Model A. My pals were as unable to explain the phenomenon as me, but it was my car and I was experiencing the hyperventilation. I got on the phone to my dad and in a breaking voice told him what had happened.

"I have three speeds in reverse and one speed forward. I didn't even touch the transmission! What's wrong with my car?"

He thought for a minute and began to laugh. I didn't think it was funny. "When we flipped it over, the ring gear ended up on the wrong side of the pinion. You'll have to take it apart again, pull the guts out from the right side and put them back in on the left."

I went out and told my friends what we had to do. But before we started, we took it out on the street and drove it backwards through all three gears just to say we did it.



# Electrical Repairs on the Model A – Finding A Bad Wire

BY HOWARD ECKSTEIN



At our recent Garage Days event, we worked together on Tony’s 1928 Phaeton to solve an electrical short and brighten the headlights on his car. Safety is very important and correcting problems is a must-do on any car with a compromised lighting system.

We used a voltmeter to find the source of his short. This is wiser than turning on the light switch and waiting for something to smoke so as to find the location of the problem. By checking continuity to ground on each of the wires, we found the short in his tail light. There should not be any continuity to ground in a wire going to a bulb.

To use the voltmeter for this test, we set the selector to Ohms, represented by the Greek letter Omega -  $\Omega$ . By disconnecting the wiring harness from the switch at the end of the steering column, we had access to all the wire ends. By using a wiring diagram, we saw which colored wire goes to which light bulb. Here’s how to do it:

1. Place one test lead anywhere on the chassis of the car or engine to get a good ground connection and the other test lead on the wire end you want to check.
2. If the reading is about 6 Ohms, that’s normal for a functioning circuit with a good light bulb in it.
3. If the reading is 0, then there is no short but an “open” circuit; if the wire goes to a light bulb, that bulb may be burned out.
4. If the reading is about .02 Ohms, you’ve found the shorted wire.

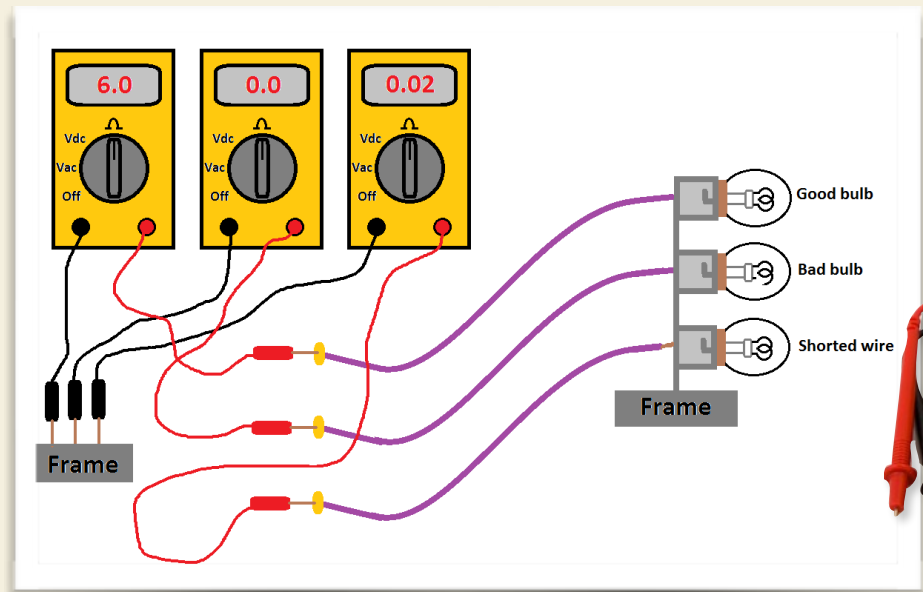



# Breaking News...

## FROM NEWSPAPERS OF THE MODEL A ERA

Today 15 Dead in Subway Disaster



**June 12, 1928** — Born Richard Morton Sherman; he became a famous songwriter and music director and wrote movie music with his brother Robert Bernard Sherman.

You may not know their names, but you know their songs. Some of the Sherman Brothers' best-known writing includes the songs from *Mary Poppins*, *Bedknobs and Broomsticks*, *The Jungle Book*, *Winnie the Pooh*, *Chitty Chitty Bang Bang*, *The Slipper and the Rose*, and the Disney theme park song "*It's a Small World (After All)*".

**June 30, 1929** — 33rd US Golf Open: Bobby Jones shoots a 294 at Winged Foot CC NY. Jones won his third U.S. Open title here in a 36-hole playoff, besting Al Espinosa by 23 strokes on the West Course. He won his fourth U.S. Open in 1930 and the grand slam. He was the most successful amateur golfer ever to compete on a national and international level. He retired at age 28.

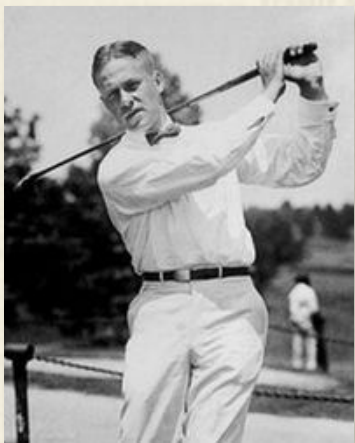

**June 7, 1930** — Respecting Negro demands, The New York Times agrees to capitalize the n in "Negro." W. E. De Bois and other activists were demanding the work negro be capitalized. He targeted local and national newspapers. He viewed it as disrespect and overtly racist. One editor of a Georgia newspaper refused saying he would never capitalize the letter "n" because it might lead to "social equality."



**June 9, 1931** — Robert Goddard patents the first rocket powered aircraft. In 1899 as a child his was sent into a cherry tree to trim the branches, instead, he started daydreaming. In his journal he wrote:

*"It was one of the quiet, colorful afternoons of sheer beauty which we have in October in New England, and as I looked toward the fields at the east, I imagined how wonderful it would be to make some device which had even the possibility of ascending to Mars..."*

That became his lifelong pursuit.

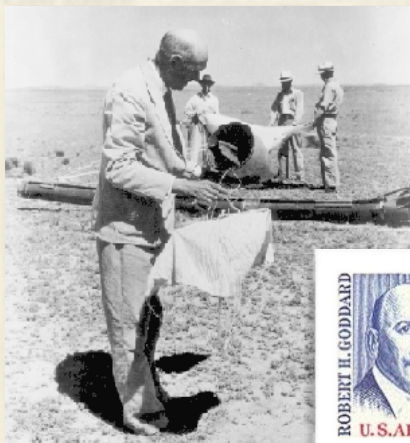



### COLLARS, CUFFS, SLEEVES AND BELTS

by Lois Przywitozski  
compliments of MAFCA  
fashion committee

The season is changing, and once again last year's wardrobe is in good condition but could be improved by an update. So, as a fashionable, but budget minded woman of the Model A era, what can you do? As always, the fashion industry has a solution for you, it's not a new idea, but it still works wonders with your wardrobe. You can purchase, or make, new collars, cuffs, sleeves, or belts for that perfect update.



The collar and cuff set on the left side of this picture is said to be "the most desirable style of the season." It is made of white linen, trimmed with lace and sells for 49 cents.

The second collar and cuff set is made of semi stiff white cotton with lace edging. This lovely collar sells for 39 cents.

*The Charles William Stores, Inc., Fall and Winter, 1928-29*



This belt, collar, and cuff set, shown in the April 1929 issue of *Woman's World* is featured as one of "the newest ideas for accessories which are easily and quickly made." The entire set, with its subtle simplicity, is made from felt.

*Woman's World, April 1929*





In the June 1930 *McCall Style News*, it was noted that “the mode has definitely gone feminine, these softening and flattering accessories play a very important part in the chic ensemble.”



The collar pattern shown here was available in small, medium and large sizes. The recommended fabrics were chiffon, pique or lingerie lawn. They were sure to add femininity and grace to the right frock with their flowing lines.

*McCall Style News*, June 1930



This sleeve pattern came in 6 sizes. Note the short puff sleeve in the upper left corner. The pattern description notes that “with the advent of the short sleeve many a frock may be remodeled attractively and made to serve another season.”

*McCall Style News*, June 1930

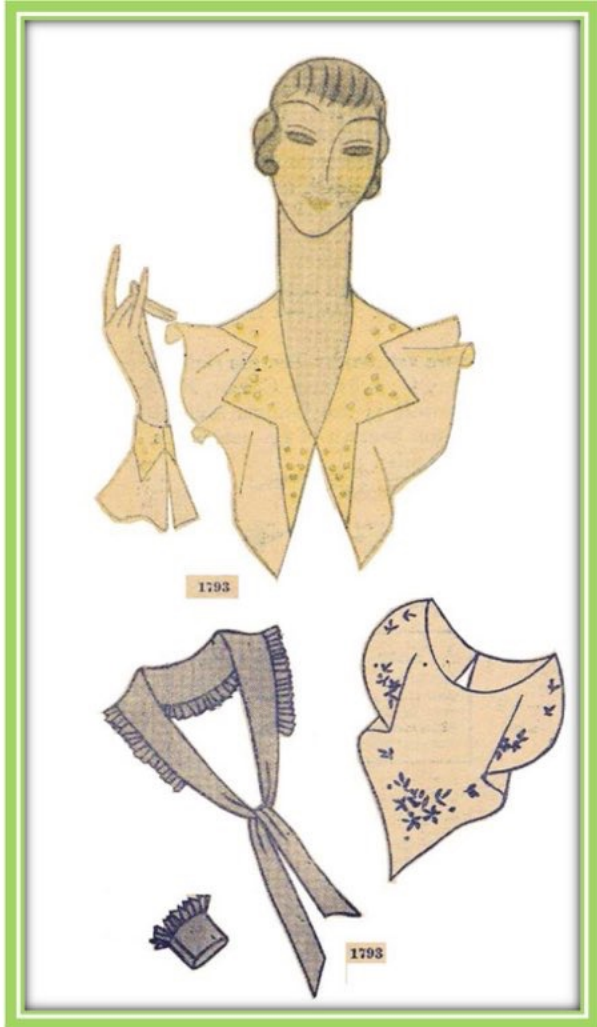

This smart collar and cuff pattern came in one size. The recommended fabrics were organdie, flat crepe or satin; some with hand embroidery, others had picoted edges or were finely pleated.

The pattern included blue transfers and sold for 35 cents.

*McCall Style News, June 1930*

#####





## Model A Ford Club of America

There are a number of websites and blogs from members of the Model A Ford Club of America that might be of interest to fellow Model A'ers. You can find these links on the MAFCA webpage or they are listed below.

If you are reading this newsletter on-line you can just click on the link and your browser should connect you with these blogs. If you are reading a printed version of the newsletter, you will have to type in the web address in your browser.

They traveled across the country in a 1929 Ford Model A. Minnesota to Kentucky for a Model A Convention. Then Chicago to California on Old Route 66. Coast Highway to Oregon to visit friends, Ferry to Vancouver Island, Pass through the Cascades, Glacier, Yellowstone, Tetons and then head for home. This trip occurred in 2013

<http://www.travelpod.com/travel-blog/29-ford-model-a/1/tpod.html>

"I am a new member and my name is Robert (Bob) Kehn of Libby Montana. I am attempting a trip from the southern most point in the continental USA (Florida) to the northern most drivable point in Alaska (Prudhoe Bay.) " This trip starts on June 1, 2014.

<http://www.keywesttoprudhoebay.com/>

The following two blogs are capturing the events of the National Tour: Lobsters and Lighthouses of Main. We can be there without having to be there. Starts June 7th.

<http://jimandjulietourmainemodela.blogspot.com/>

<http://2015mafcanationaltour.blogspot.com/2015/05/getting-ready-to-roll.html>

- June 8th-12th — "We would like to invite you to the 2015 Regional Meet, "A's in N.W. MISSOURI." Join us for a fun-filled week of activities and tours. We will be taking road trips to scenic locations such as Conception Abby, Lost Creek Wind Farm and Shatto Dairy. Details and registration information can be found on our regional website [www.2015regional.com](http://www.2015regional.com)."



- June 23-27th — Northwest Regional Meet, Walla Walla Washington. The theme is "Wine With Us in Walla Walla." See [our website](#) for additional information.



- June 7-12th — 2015 MAFCA National Tour: Lobsters and Lighthouses of Maine, Kennebunkport, Maine. If you would like to know more about it, refer to their webpage at:



- <http://www.mainemodelafordclub.com>

### 15 FOR 15

Your new Board of Directors has set a goal to increase MAFCA membership to 15,000 in 2015.



To join you (562)-697-7212; can call: mail your payment to the address below or join online at: [https://mafca.com/cart/index.php?mafca\\_new\\_member=yes](https://mafca.com/cart/index.php?mafca_new_member=yes).



“And Now A Word From Our Sponsors...”

**MOST** SEARCHED, PURCHASED, LOYAL. AUTOMOTIVE BRAND

2015 FOCUS    2015 FUSION    2015 ESCAPE    2015 F-150

\*Searched based on Google 2014 Year in Search™. Purchased based on 2014 C/V Sales Data. Loyal based on J.D. Power's 2014 Customer Loyalty Study. Ford had the greatest percentage of owners who returned to market and purchased or leased another Ford vehicle in the 2014 model year.

*Jerry H. Miller*  
**Ford Lincoln PROVO**  
 Driven By You.

**CAR SHOW**  
 and Drive-In Movie

**NOW PLAYING**  
*American Graffiti*

Car Show at 4:00 pm  
 Drive-In Movie at Dusk

**JUNE 27TH**  
 ELK Ridge City Park

**ARROWHEAD UPHOLSTERY**  
 More info & Pre-registration:  
 ArrowheadUpholstery.net  
 or call 801-609-8744

**Maple Mountain Insurance Services**

**BEST OF STATE**  
 COLLISION AUTO BODY PAINT REPAIR  
**MARTINS**  
**OREM SALEM**

Please Think of Our Sponsors When You Need these Services!